



NISSINDO

Model: **LX-2020 G2** Dual Hand-held
VHF Wireless Microphone System

Installation and Operation















2-in-1 Base Receiver Module with 2 Wireless Microphones System

This wireless system may operate on some VHF frequencies that are not authorized in your area. Please contact the relevant governmental department in your country to obtain information on the authorized VHF frequencies for the wireless system in your area.



CONTENTS

| | | | |
|--|---|--------------|--|
|  | INTRODUCTION..... | 1 | |
|  | SYSTEM FEATURES..... | 1 | |
|  | PACKAGE ACCESSORIES..... | 2 | |
|  | 2-in-1 BASE MODULE..... | 3 | |
| | • Controls and Functions..... | 3~4 | |
| | • Hardware Setup..... | 5 | |
|  | HAND-HELD MICROPHONE..... | 6 | |
| | • Controls and Functions..... | 6 | |
|  | OPERATION..... | 7 | |
| | • How to Insert/change Batteries of Microphone..... | 7 | |
| | • How to Turn On/Off Microphone..... | 8 | |
| | • How to Interchange Microphone Head..... | 8 | |
|  | TECHNICAL SPECIFICATION..... | 9 | |
|  | BODY-PACK MICROPHONE (Optional)..... | 10~11 | |
|  | TROUBLESHOOTING..... | 12~13 | |
|  | APPENDIX..... | 14 | |
|  | WARRANTY..... | 15 | |
|  | CONTACT INFORMATION..... | 16 | |



INTRODUCTION

The Nissindo engineering team created the VHF Wireless microphone model LX-2020 and introduced it into the market worldwide 13 years ago. It is a classic. So this year we decided to introduce the next generation: the LX-2020 G2. We hope the consumers will benefit from our improvements and upgrades.

The VHF Wireless microphones LX-2020 G2 give a more comfortable feel to the vocal music industry. Nissindo specializes in Karaoke singing and affordable for the user, with a balanced XLR output for each channel and also has unbalanced mixed channels out from the receiver of our new LX-2020 G2. With years of experience designing wireless microphone system, we at Nissindo understand the problem with short battery life. Through intensive research we have developed a better power management system to help extend our wireless microphone battery life. Now equipped with AA size battery casing the LX-2020 G2 allows for more user friendly functions resulting in longer lasting performances. Material used on the microphones allows an easy grip handling and now have a power slider equipped with a LED that indicates when battery is running low.

It is simply the best solution for home and professional karaoke performance.



SYSTEM FEATURES

1. Equipped with wireless technology and VHF dual-channel in a 2-in-1 Base Module to pick up weak signals and prevent signal interference
2. PLL pilot circuit design
3. Fixed frequency
4. Dynamic cartridge, bright and clear sound, long receive distance
5. Receiver distance in 80m
6. Clear voice delivering crystal clearer sound just like a wired microphone.
7. Light weight mounting design for portability
8. Adjustable antennas for better signal receiving
9. AA batteries for easy usage.



PACKAGE ACCESSORIES

The package comes with one 2-in-1 Base Module [Receiver], two handheld microphones, one DC adaptor, one unbalance audio cable, and four AA batteries.

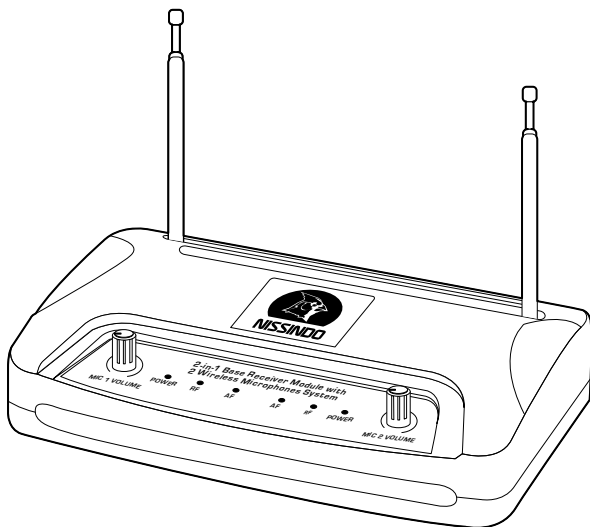

2-IN-1 BASE MODULE [RECEIVER]: 1 SET

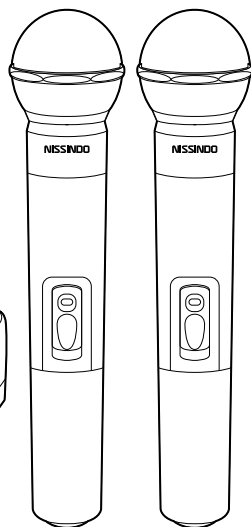

HANDHELD MICROPHONE: SET of 2

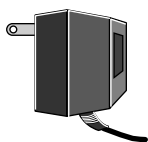

DC POWER ADAPTOR: 1 UNIT



AA (1.5V) BATTERY: 4 UNITS

NOTE DC-POWER USAGE: This wireless microphone system is designed specifically for the North American market, which uses 120V for DC power. For usage in Asia or Europe, please change it to 220V by an adaptor with DC 14V output 500mA.

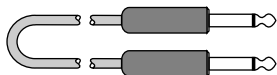

AUDIO CABLE (FOR MIXED OUTPUT): 1 UNIT



For better quality connections, a XLR to XLR cable is highly recommended.



2-in-1 BASE MODULE [RECEIVER]

CONTROLS AND FUNCTIONS

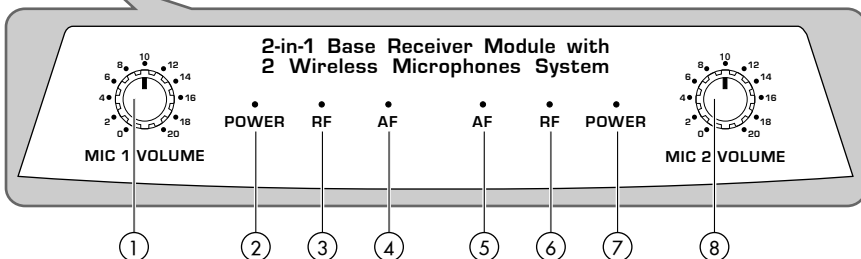

FRONT PANEL:

1. MIC 1 VOLUME CONTROL: Controls Microphone 1 volume.
2. MIC 1 POWER INDICATOR: Lights up when receiver is powered ON.
3. MIC 1 RF INDICATOR: Lights up when microphone is powered ON.
4. MIC 1 AF INDICATOR: Lights up when receive signal from microphone.
5. MIC 2 AF INDICATOR: Lights up when receive signal from microphone.
6. MIC 2 RF INDICATOR: Lights up when microphone is powered ON.
7. MIC 2 POWER INDICATOR: Lights up when receiver is powered ON.
8. MIC 2 VOLUME CONTROL: Controls Microphone 2 volume.

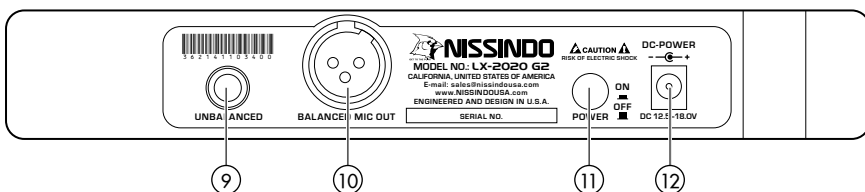

REAR PANEL:

9. MIXED OUTPUT: unbalanced 1/4" audio output.
10. BALANCED OUTPUT: balanced XLR audio output.
11. POWER BUTTON: Turns the system ON/OFF.
12. POWER SUPPLY: Removable adapter with DC12.5~18V 200mA.



HARDWARE SETUP

HOW TO CONNECT AUDIO OUTPUT:

There are two rear outputs as shown in the below diagram:

MIXED OUTPUT is unbalanced audio output for MIC 1 & MIC 2 using 1/4" connection. When using this output, MIC 1 and MIC 2 have to share a signal. To produce different effects on each microphone, MIC 1 and MIC 2 need their own signals which can be done by using XLR connections.

BALANCED OUTPUT is balanced audio output for MIC 1 & MIC 2 using XLR connection.



We highly recommend using balanced XLR connections if the distance between the microphone receiver and the mixer is more than 10 feet. The grounding of the balanced XLR connection delivers better quality signal by reducing noise.

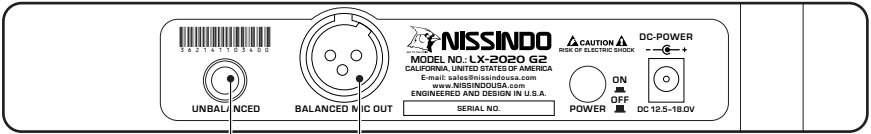

MIXED OUTPUT
(MIC 1 & 2 UNBALANCE)

MIC 1 & 2 BALANCED OUTPUT (BALANCED XLR)

UHF WIRELESS SYSTEM DIAGRAM:

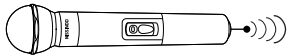

MIC 1 HANDHELD MICROPHONE

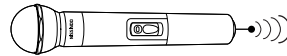

MIC 2 HANDHELD MICROPHONE



REAR VIEW

BALANCED CONNECTION

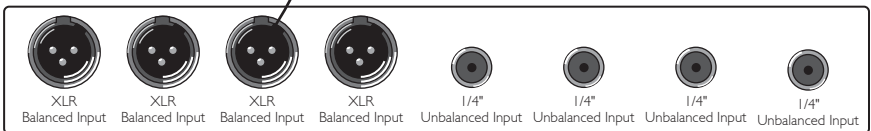

AUDIO MIXER AMPLIFIER OR A KARAOKE UNIT INPUT TERMINAL

HOW TO CONNECT DC-POWER:

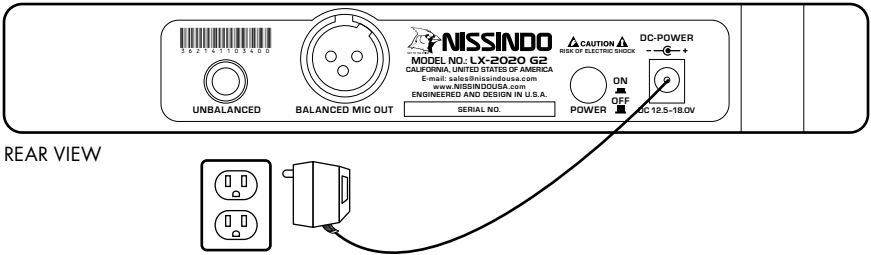

For North America Market, use 120V, DC 12.5~18V 200mA adaptor. For market outside North America, use 220V~ 240V DC adaptor with a maximum battery capacity of 200mA.

NOTE ▶ Please make sure to use the right DC adaptor. Otherwise, it may damage the 2-in-1 Base Module because their maximum battery capacity is different. The product warranty will be voided if there is damage caused by using the wrong DC adaptor.

OPTIONAL 19" RACK MOUNT KIT:

To put the system onto a mount-kit, please follow the diagram below. Our special design feature allow it to be mounted on a DJ rack.

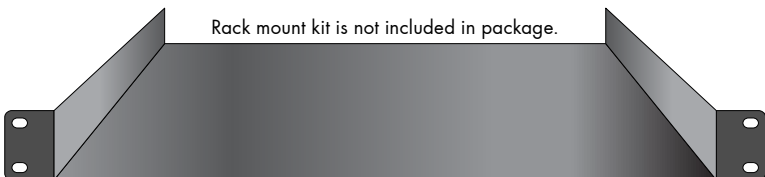
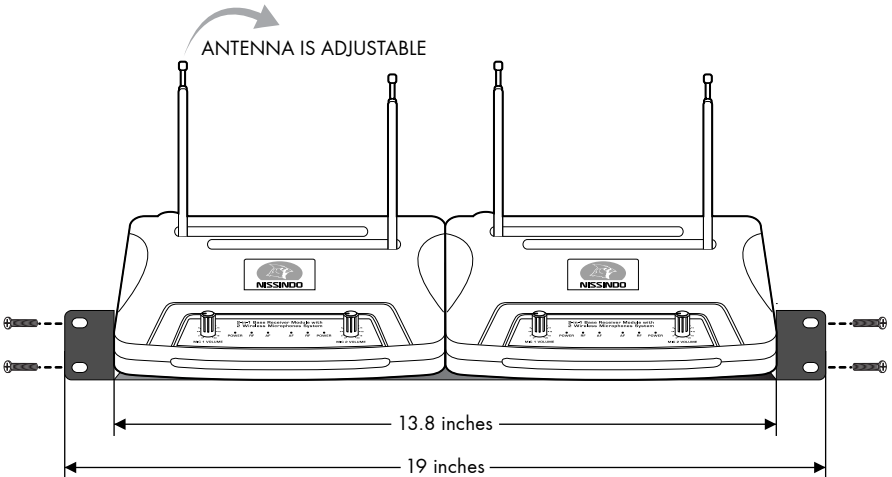



HANDHELD MICROPHONE

CONTROLS AND FUNCTIONS

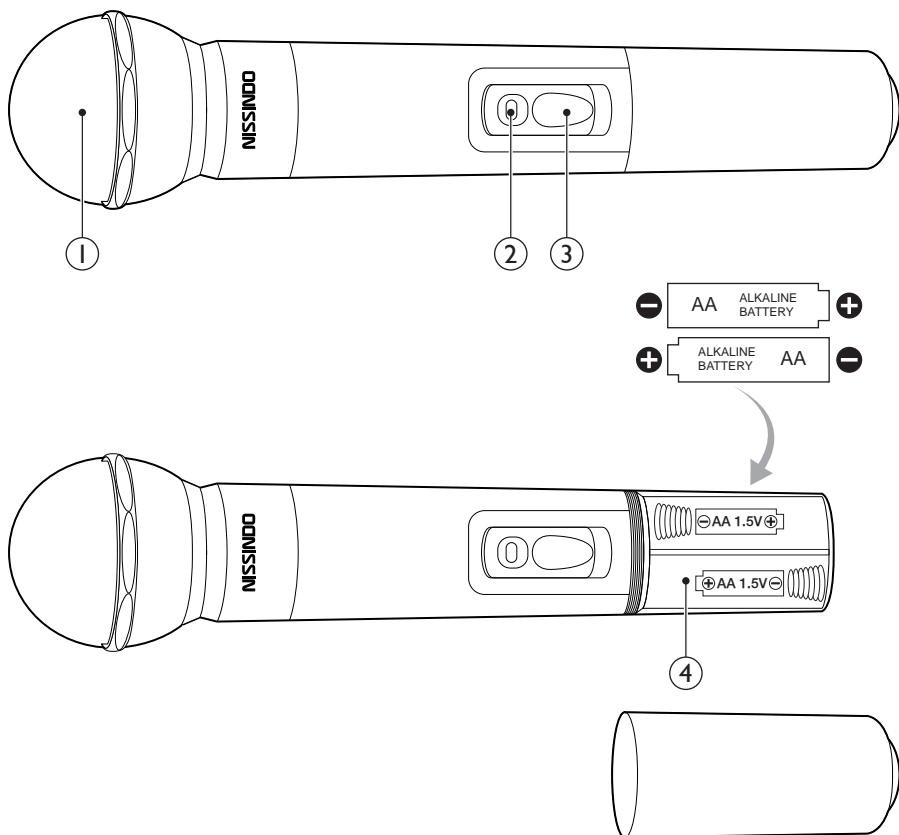

1. INTERCHANGEABLE MICROPHONE HEAD
2. POWER INDICATOR
3. POWER ON/OFF SWITCH BUTTON: Push the power switch to turn ON/OFF the microphone.
4. BATTERY SLOTS: Insert 2x1.5V AA battery or 2x1.2V rechargeable battery.



OPERATION

HOW TO INSERT/CHANGE BATTERIES OF MICROPHONE

STEP 1: Twist open battery cover.

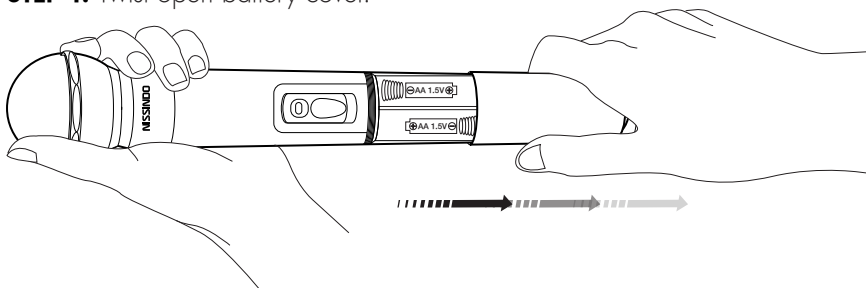

STEP 2: Use one hand to hold onto the top of the Microphone, and the other hand to slide 2x1.5V AA batteries into battery slot. Be careful not to drop Microphone while inserting batteries.

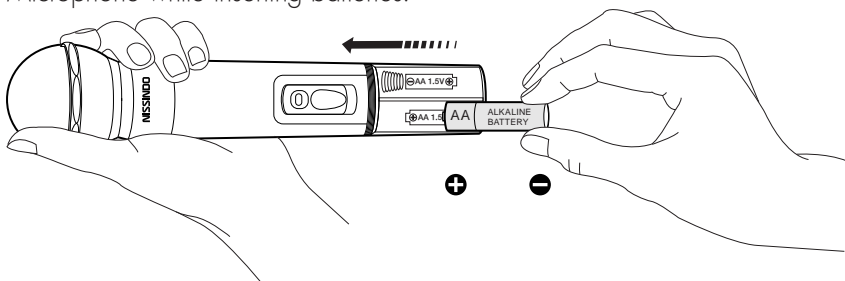

! Make sure to follow the polarity of the battery according to the battery slots.

Good

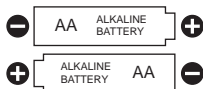

No Good

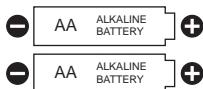

No Good

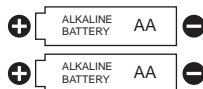

STEP 3: Twist back battery cover.

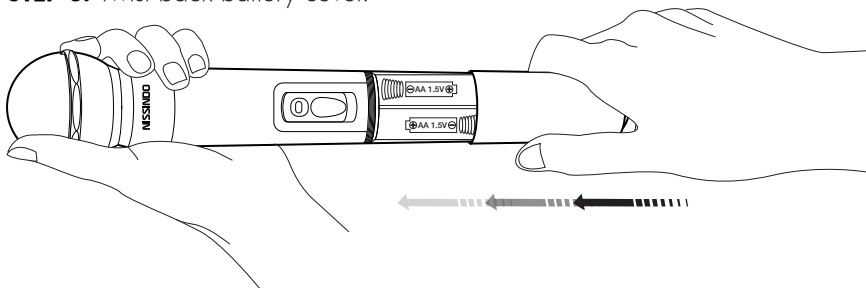

HOW TO TURN ON/OFF MICROPHONE

Push the power switch to turn ON/OFF the microphone.

NOTE ▶ If the microphone cannot be turned on, please check the battery. It may be very low. Typical new full battery life is 4~6 hours with our system, otherwise, the batteries might be defective or near expiration date.

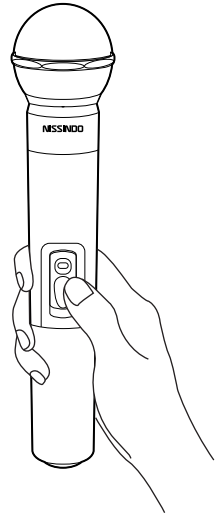

HOW TO INTERCHANGE MICROPHONE HEAD

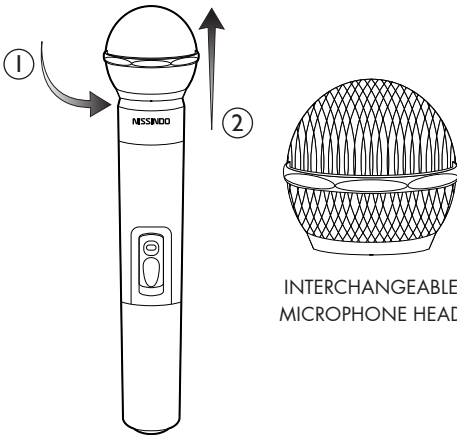

NOTE ▶

Replacement parts (such as the microphone head as shown on the left) can be purchased from any of our authorized dealers.



TECHNICAL SPECIFICATION

A. TECHNICAL FEATURE OF THE 2-IN-1 BASE MODULE:

1. Frequency Range: VHF 216~270 MHz
2. Frequency Stability: +/-0.005%
3. Image Interfere Rate: >80dB
4. S/N Ratio: >105dB (1Khz)
5. Sensitivity: -107dBm
6. Audio Output Impedance: 600Ω
7. Audio Output Level: -12dB
8. Audio Output Level: Unbalanced Out: 0~+/-400mV
Balanced Out: 0~+/-200mV
9. Power Supply: DC 12.5~18V/200mA, AC 120V (For 220V, you may need to change to a 220V~240V DC adaptor)
10. Receiver Dimensions (WxHxD): 8.7 x 1.6 x 5.1 (inches) / 22 x 4 x 13 (cm)
11. Package Dimensions (WxHxD): 15 x 11.8 x 2.4 (inches) / 38 x 30 x 6 (cm)
12. Shipping Weight: 3 lbs / 1.4 kg

B. TECHNICAL FEATURE OF THE MICROPHONE:

1. Frequency Preparation: PLL
2. Frequency Stability: +/-0.005%
3. Image Interfere Rate: >=102dB
4. Frequency Response: 30Hz~18kHz
5. S/N Ratio: <60dB
6. RF Output: 10mW
7. Current: <100mA
8. Battery Voltage: 2 x AA 1.5V Alkaline Battery
9. Continuous Using: 8 Hours (GP) 2 x AA 1.5V Battery
10. Microphone Dimensions (WxH): 9.5 x 2.2 (inches) / 24 x 5.5 (cm)

C. THIS SYSTEM INCLUDES THE FOLLOW:

- 2-in-1 Base Module: 1 Set
- DC-Power Adaptor: 1 Unit
- Audio Cable: 1 Unit
- Handheld Microphone: 2 Sets
- AA 1.5V Battery: 4 Units
- Instructional Manual: 1 Unit



BODY-PACK MICROPHONE SYSTEM SPECIFICATION (Optional)

NAMES & FUNCTION:

Body-Pack Microphone System (including Lavalier Mic. and Headset Mic.)

Outside Picture

1. Antenna
2. 4-pin Microphone Input Jack
3. LCD Digital Display
4. IR Port: Receives infrared beam to synchronize frequencies. IR when using multiple systems, only one microphone port should be exposed at a time
5. Battery Cover
6. Tie-Clip
7. Microphone Extension Jack

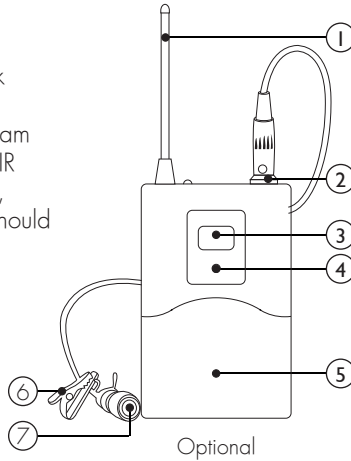

Side-face Picture

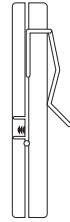

Optional

Inside Picture

1. Power/Mute indicator
 - Green: Ready
 - Amber: Mute Open
 - Flashing Red: IR is transmission in process
 - Glowing Red: Low battery power
 - Pulsing Red: Battery dead (microphone cannot be turned off until batteries are changed)
2. Power ON/OFF/mute switch Button: Press and hold the microphone for 3 seconds to turn power ON/OFF. Press and release to mute or un-mute the microphone.
3. Adjustment switch
4. Battery Slot

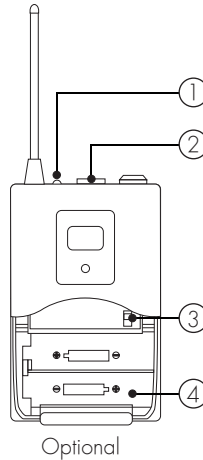

Lavalier Mic.

(Accessories)

1/4" to mini 3-pin lavalier cable

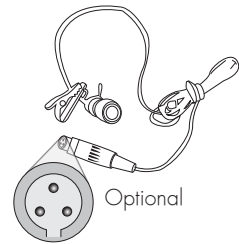

Headset Mic.

(Accessories)

1/4" to mini 3-pin lavalier cable



Apical Panel

1. Antenna Jack
2. Power/Mute indicator
3. Power Switch
4. Microphone Input Jack

Body-pack Microphone Top View

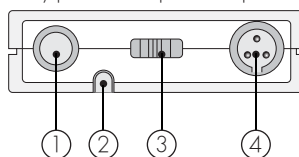

HOW TO INSERT BODY-PACK MICROPHONE BATTERIES

STEP 1: Open battery cover.

STEP 2: Insert 2 AA alkaline batteries. 2 alkaline batteries are expected to use for about 8 hours.

Make sure that you insert batteries correctly, as shown in picture. When the microphone body-pack light glows red, the batteries should be changed immediately.

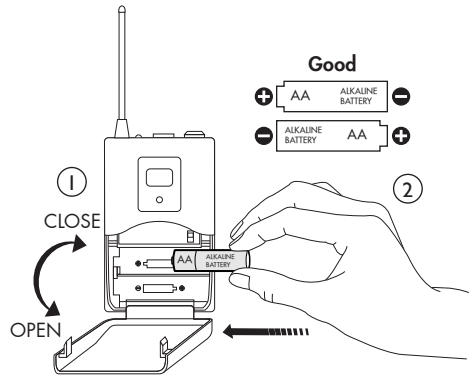

HOW TO WEAR BODY-PACK MICROPHONE

The microphone can be buckled to the belt or the guitar band. For best result, the microphone should be pushed down until the belt is close to the base of microphone.

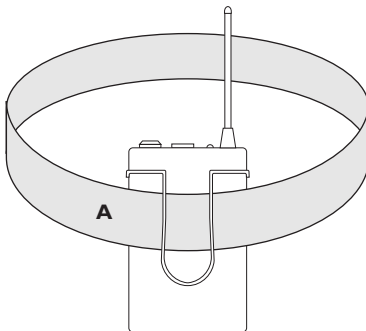

MICROPHONE BODY-PACK
REAR VIEW

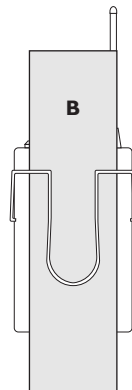

MICROPHONE BODY-PACK
REAR VIEW

ADJUSTMENT GAIN

Three gain settings are available. Choose the appropriate setting for your instrument.

- MIC: for the microphone adjustment
- 0: Guitar with passive pickups
- -10: Guitar with active pickups

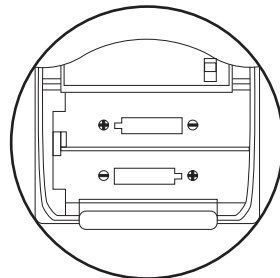



TROUBLESHOOTING

! CAUTION: Before troubleshooting any symptoms make sure the equipments are in the “OFF” position.

1. SYMPTOM: NO SOUND COMING FROM MICROPHONE

A. CAUSE: There is no indication of signal.

- Turn microphone to “OFF” position. Check if batteries are inserted correctly.
- If batteries are inserted correctly, but there is no power, insert new batteries.
- The volume may be turned to a low level.

B. CAUSE: The receiver is unpowered.

Make sure the power adapter is connected properly and there is power coming from the power outlet.

C. CAUSE: There is no indication of AF signal.

Turn off the receiver and make sure it is properly connected to the mixer or amplifier. If it is, slowly turn the volume higher.

D. CAUSE: There is no indication of RF signal.

If there is no indication of RF signal there may be interference between the receiver and the microphone. Change the channel between the microphone and receiver otherwise; Adjust the antenna of the receiver and/or move away objects between receiver and the microphone .

2. SYMPTOM: ONE OR MORE OF THE MICROPHONE IS NOT WORKING, CHECK THE SOLUTIONS FOR CAUSES A~D ABOVE.

3. SYMPTOM: RANDOM NOISE COMING OUT FROM MICROPHONE

CAUSE: There are interference within your area.

Stand further away from your speaker.

4. SYMPTOM: THE MICROPHONE SUDDENLY HAS NO SOUND AND THE RECEIVER LCD LIGHT IS OFF.

Make sure the AC power adapter is securely plugged into the electrical outlet and into the DC input connector on the rear panel of the receiver. Make sure the AC electrical outlet works and is supplying the proper voltage.

5. SYMPTOM: THE MICROPHONE SUDDENLY HAS NO SOUND BUT THE RECEIVER SHOWS RF SIGNAL.

CAUSE: The microphone out lead is damaged or disconnected.

To fix it, open the microphone head cover to check on the microphone out lead and re-connect the wire by welding. If it does not work, replace the microphone out lead.

6. SYMPTOM: THE MICROPHONE DISTORTION LEVEL IS INCREASING GRADUALLY.

CAUSE: The microphone batteries are running out.

Replace the microphone batteries.

7. SYMPTOM: POOR SIGNAL

CAUSE: When the 2-in-1 Base Module and microphone are placed in different rooms made of concrete wall. This would cause poor signal.

Your audio equipment is close to the police, fire or radio stations.



APPENDIX

LX-2020 G2 FCC FREQUENCY: 216.000~270.000 MHz

VHF Frequencies Available for Use for Home Electronics in North America

The RF radio frequencies used in the transmission of wireless information are closely regulated in most countries including North America. A lot of countries strictly enforce their regulations stating which RF frequencies are available for use for certain device, so it can help limit the amount of radio frequency interference in all wireless communications.

FCC Information to User for Reference

This equipment is designed in compliance with the limits for a Class A digital device pursuant to part 15 of the FCC Rules from the United States of America. These limits are designed to provide protection against harmful interference when the equipment is operated in public environment. This equipment generates, uses, and can radiates radio frequency energy and, if not installed and used in accordance with the instruction manual, may cause harmful interference to radio communications. Operation of this equipment in a residential area may cause harmful interference, so the user will have to correct the interference at his/her own expense.



WARRANTY

One-Year Limited Warranty for Home Use Equipment

Our one-year warranty applies to speakers, amplifiers, mixers and microphones for home use only. It covers both parts and labors. The warranty becomes effective on the date of your purchase.

Our warranty only covers defects due to product defectiveness with free of defects in materials or workmanship. However, our warranty does not cover defects due to normal wears, damage in transit, improper use, abuse or failure to follow the proper instructions for maintenance. This warranty is void in the event of unauthorized repairs, alternations, modifications and removing of the product label.

Please also note that our warranty does not cover any shipping cost for the return of defective products to us for inspection, repair and maintenance. Our warranty for Nissindo products can only be executed in North America.

NOTE ► Our warranty does not cover the battery for wireless microphone products.

90-Day Limited Warranty for Public and Commercial Use Equipment

Our 90-day warranty applies to speakers, amplifiers, mixers and microphones for both public and commercial use such as restaurant, coffee shop, KTV nightclub, church and school, etc. It covers both parts and labors. The warranty becomes effective on the date of your purchase.

To Register Your Warranty

Please submit the warranty card that comes with your unit; it is also download on our website. However, we need the invoice for your purchase in order to process this warranty. You may also register your warranty online. Please visit our website at www.NissindoUSA.com.

PRECAUTION

1. If using more than one microphone system, please select the operating frequency or signal channel carefully so as to avoid disturbing.
2. The input power voltage of the 2-in-1 Base Module is 110V/120V ($\pm 10\%$). If it is too low or too high, it will affect the work of the machine.
3. When installing batteries, reversing the electrode will damage the machine.



Caution: To reduce the risk of electrical shock, do not remove the cover (or back). No user serviceable parts inside: refer servicing to qualified personnel.

Warning: To reduce the risk of fire or electrical shock, do not expose this appliance to rain or moisture.



This symbol, wherever it appears, alerts you to the presence of uninsulated dangerous voltage inside the enclosure voltage that may be sufficient to constitute a risk of shock.



This symbol, wherever it appears, alerts you to important operating and maintenance instructions in the accompanying literature. Read the manual.



CONTACT INFORMATION

MAILING ADDRESS



NISSINDO
29300 Kohoutek Way #150
Union City, CA 94587
U.S.A.

TELEPHONE NUMBERS



USA Region
USA Toll Free: 1-800-318-2218
Sales & Marketing: 510-477-9955
Customer Service: 510-477-9955

FAX NUMBERS



USA Region
Sales & Marketing: 510-477-9922
Customer Service: 510-477-9922

WORLD WIDE WEB



E-mail: sales@nissindousa.com
Website: www.NissindoUSA.com

NISSINDO is a leader in the Audio and Karaoke equipment industry. We are committed to offering you high quality audio products. Unlike any others brand, we deliver the best cost and value to you directly. For the latest update information including operation manuals, installation instructions, hook-up diagram and other new technologies updates etc. please visit us at our website www.Nissindousa.com.

Comments to **NISSINDO**
29300 Kohautek Way #150
Union City, CA 94587 U.S.A.
E-mail: sales@nissindousa.com
Website: www.nissindousa.com



